

Commercial eF Series[®] Ultra High Efficiency Gas Water Heater



The eF Series[®] Models feature:

- **Thermal Efficiency up to 99.1%**—Ultra High Efficiency results in less fuel consumption and greater hot water recovery.
- **ICON HD™**—Intelligent proven design combines temperature control, diagnostic codes, and system ignition functions into a single control board with a digital LCD display.
- **ENERGY STAR[®] Models Available**—EF60T125 & EF100T (150,199,250,399) Models.
- **Factory Installed Hydrojet[®] Sediment Reduction System**—Cold water inlet sediment reducing device helps prevent sediment build up in the tank.
- **Direct Spark Ignition**—For improved operational dependability and durability.
- **Operation Mode**—Two different digitally displayed operation modes have the capability of adjusting the temperature setting up to 180°F (82°C), and adjusting the degree setting (°F to °C, or °C to °F).
- **Service Mode**—Eight different digitally displayed service screens can be easily cycled through by pressing the select button. There is the capability of adjusting the temperature setting up to 180°F (82°C), adjusting the degree setting (°F to °C, or °C to °F), locking the maximum temperature setting that can be adjusted in operation mode, displaying the temperature sensor reading, displaying the flame current, and displaying diagnostic codes.
- **Premix Power Burner**—A self compensating negative regulation system automatically increases or decreases fuel flow when a change in combustion air is detected. This provides the range for optimum combustion and efficiency (automatic high altitude compatibility).
- **Flexible Venting**—The eF Series[®] can vent vertically or horizontally with either 2", 3" or 4" (51mm, 76mm or 107mm) PVC, CPVC or ABS (not approved for Canada) vent pipe, and is approved for direct vent closed combustion applications, or those applications that require inside air for combustion. The eF Series[®] is also approved for unbalanced venting, which means the air intake pipe doesn't have to be vented the same distance as the exhaust.
- **Ultra Quiet Operation.**
- **A Single Exhaust Pressure Switch.**
- **1" (25mm) NPT Side Connections for Space Heating.**
- **Sanitizing Capability**—Temperature setting up to 180°F (82°C).
- **Complies with the latest ultra-low NOx requirement (14 ng/J NOx limit).**
- **ASME Code Available on All Models.**
- **NSF Construction Available.**
- **T&P Relief Valve**—Installed.
- **Low Restrictive Brass Drain Valve**—Durable tamper proof design.

Endorsed by



Photo is of
EF-60T-199E-3N

FEATURING:



3 or 5-Year Limited Tank Warranties / 1-Year Limited Warranty on Component Parts.

For more information on warranty, please visit www.bradfordwhite.com
For products installed in USA, Canada and Puerto Rico. Some states do not allow limitations on warranties.
See complete copy of the warranty included with the heater.

Commercial Gas High Efficiency Water Heater

eF Series® Additional Equipment Features:

Three Pass Heat Exchanger System—The three pass Heat Exchanger system keeps the hot combustion gases moving at a high velocity. The combination of high turbulence and velocity causes an enormous rate of heat transfer into the water.

Submerged Combustion Chamber—Submerging the combustion chamber in the center of the water storage tank minimizes radiant heat loss and improves efficiency.

Zero Inch Clearance—The eF Series® jacket is cool to the touch and is approved for zero inch clearance to combustibles for unsurpassed installation flexibility.

Vitraglas® Lining—An exclusively engineered enamel formula that provides superior tank protection from the highly corrosive effects of hot water. This formula (Vitraglas®) is fused to the steel surface by firing at a temperature of over 1600°F (871°C).

Protective Magnesium Anode Rods—Each eF Series® model has multiple anodes to provide added protection against corrosion for long trouble-free service (EF100T399 has two powered anode rods).

Factory Installed Hydrojet® Sediment Reduction System—Cold water inlet sediment reducing device helps prevent sediment build up in tank.

Water Connections—Factory-installed true dielectric fittings extend water heater life and simplify water line connections.

Hand Hole Cleanout—Allows inspection of tank interior and facilitates the removal of sediment deposits.

E.C.O.—A manual re-set Energy Cut Off (E.C.O) shuts off all gas in event of an overheat condition. The ECO is manually resettable.

Non-CFC Foam Insulation—Covers the sides and top of tank, reducing the amount of heat loss. This results in less energy consumption, improved operation efficiencies and jacket rigidity.

2" Vent Pipe	EF-60T-125		EF-60T-150 EF-100T-150		EF-60T-199 EF-100T-199	
	Power Direct Vent	Power Vent	Power Direct Vent	Power Vent	Power Direct Vent	Power Vent
Max. Intake Length	15 ft.	N/A	15 ft.	N/A	15 ft.	N/A
Max. Exhaust Length	15 ft.	30 ft.	15 ft.	30 ft.	15 ft.	30 ft.

3" Vent Pipe	EF-60T-125 EF-100T-150		EF-60T-150 EF-100T-199		EF-60T-199 EF-100T-250		EF-100T-300		EF-100T-399	
	Power Direct Vent	Power Vent	Power Direct Vent	Power Vent	Power Direct Vent	Power Vent	Power Direct Vent	Power Vent	Power Direct Vent	Power Vent
Max. Intake Length	60 ft.	N/A	50 ft.	N/A	40 ft.	N/A	30 ft.	N/A	25 ft.	N/A
Max. Exhaust Length	60 ft.	120 ft.	50 ft.	100 ft.	40 ft.	80 ft.	30 ft.	60 ft.	25 ft.	50 ft.

4" Vent Pipe	EF-60T-125 EF-100T-150		EF-60T-150 EF-100T-199		EF-60T-199 EF-100T-250		EF-100T-300		EF-100T-399	
	Power Direct Vent	Power Vent	Power Direct Vent	Power Vent	Power Direct Vent	Power Vent	Power Direct Vent	Power Vent	Power Direct Vent	Power Vent
Max. Intake Length	85 ft.	N/A	75 ft.	N/A	65 ft.	N/A	55 ft.	N/A	50 ft.	N/A
Max. Exhaust Length	85 ft.	170 ft.	75 ft.	150 ft.	65 ft.	130 ft.	55 ft.	110 ft.	50 ft.	100 ft.

6" Vent Pipe	EF-100T-399	
	Power Direct Vent	Power Vent
Max. Intake Length	120 ft.	N/A
Max. Exhaust Length	120 ft.	240 ft.

Air intake cannot exceed exhaust by more than 30 ft. in any venting situation. Subtract 5 ft. for each additional 90° elbow.

eF Series® Optional Equipment Features:

Maxitrol Gas Pressure Regulating valve—Ensures proper supply pressure to eF unit of 7" to 11" W.C. (provided incoming pressure is between 1/2 and 2 psi). This can be ordered as a separate part, or as part of the heater. For the separate part, please use p/n 243-45517-00. Part is included with EF100T399 model.

NSF Compliance Kit—p/n 265-44542-04.

Low Inlet Gas Pressure Option—Pre-assembled to allow operation with natural gas inlet pressure down to 3.5" w.c. (Not available on EF-100T-300/399E-3N(A) models or any size propane models.)

Optional Honeywell EnviraCOM™ Alarm Module—Provides indication (contacts are closed) when an alarm is present via normally open contacts (rated for up to 24 VAC). Kit Number – 265-51961-00.

Concentric Vent Kit Termination—3" termination fitting provides for only one exit opening through wall or roof (p/n 239-44069-01).

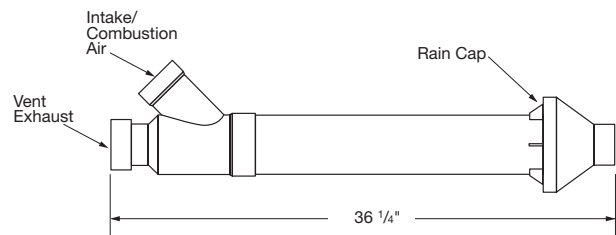

p/n 239-44069-01
p/n 239-44069-02 (for 2" vent pipe only)

Commercial Gas High Efficiency Water Heater

eF Series® Models

NATURAL GAS AND LIQUID PROPANE GAS

Meet or exceed ASHRAE 90.1b (current standard) C.E.C. Listed

Model Number	Capacity		Input		Therm. Eff. %	A Floor to Top of Heater in.	B Jacket Dia. in.	C Floor to Hot Water Conn. in.	D Floor to Cold Water Conn. in.	E Floor to Gas Conn. in.	F Floor to Vent Conn. in.	G Floor to Air Intake Conn. in.	H Floor to T&P Conn. in.	Water Conn. Dia. in.	Gas Conn. Dia. in.	Relief Valve Open in.	Approx. Shipping Weight lbs.
	U.S. Gal.	Imp. Gal.	Nat. BTU/Hr. Input	LP BTU/Hr. Input													
EF-60T-125E-3N(A)	60	50	125,000	125,000	96.0	57	28 ¹ / ₄	42 ¹ / ₂	12 ⁷ / ₈	53 ¹ / ₂	5	52 ¹ / ₂	40	1 ¹ / ₂	3/4	3/4	570
EF-60T-150E-3N(A)	60	50	150,000	150,000	93.0	57	28 ¹ / ₄	42 ¹ / ₂	12 ⁷ / ₈	53 ¹ / ₂	5	52 ¹ / ₂	40	1 ¹ / ₂	3/4	3/4	570
EF-60T-199E-3N(A)	60	50	199,999	199,999	92.0	57	28 ¹ / ₄	42 ¹ / ₂	12 ⁷ / ₈	53 ¹ / ₂	5	52 ¹ / ₂	40	1 ¹ / ₂	3/4	3/4	570
EF-100T-150E-3N(A)	100	83	150,000	150,000	99.1	77 ⁵ / ₈	28 ¹ / ₄	62 ¹ / ₂	12 ⁷ / ₈	74 ³ / ₄	5	73 ¹ / ₈	60	1 ¹ / ₂	3/4	3/4	900
EF-100T-199E-3N(A)	100	83	199,999	199,999	98.5	77 ⁵ / ₈	28 ¹ / ₄	62 ¹ / ₂	12 ⁷ / ₈	74 ³ / ₄	5	73 ¹ / ₈	60	1 ¹ / ₂	3/4	3/4	900
EF-100T-250E-3N(A)	100	83	250,000	250,000	97.0	77 ⁵ / ₈	28 ¹ / ₄	62 ¹ / ₂	12 ⁷ / ₈	74 ³ / ₄	5	73 ¹ / ₈	60	1 ¹ / ₂	3/4	1	900
EF-100T-300E-3N(A)	100	83	300,000	300,000	92.0	77 ⁵ / ₈	28 ¹ / ₄	62 ¹ / ₂	12 ⁷ / ₈	74 ³ / ₄	5	73 ¹ / ₈	60	1 ¹ / ₂	3/4	1	900
EF-100T-399E-3N(A)	100	83	399,999	399,999	94.0	77 ⁵ / ₈	28 ¹ / ₄	63	13	74 ¹ / ₄	5	73 ¹ / ₈	60	1 ¹ / ₂	1	1	950

Model Number	Capacity		Input		Therm. Eff. %	A Floor to Top of Heater mm.	B Jacket Dia. mm.	C Floor to Hot Water Conn. mm.	D Floor to Cold Water Conn. mm.	E Floor to Gas Conn. mm.	F Floor to Vent Conn. mm.	G Floor to Air Intake Conn. mm.	H Floor to T&P Conn. mm.	Water Conn. Dia. mm.	Gas Conn. Dia. mm.	Relief Valve Open mm.	Approx. Shipping Weight kgs.
	Liters		Nat. kW/Hr. Input	LP kW/Hr. Input													
EF-60T-125E-3N(A)	227		36.6	36.6	96.0	1448	718	1087	327	1359	127	1334	1016	38	19	19	259
EF-60T-150E-3N(A)	227		43.9	43.9	93.0	1448	718	1087	327	1359	127	1334	1016	38	19	19	259
EF-60T-199E-3N(A)	227		58.6	58.6	92.0	1448	718	1087	327	1359	127	1334	1016	38	19	19	259
EF-100T-150E-3N(A)	379		43.9	43.9	99.1	1972	718	1588	327	1899	127	1857	1524	38	19	19	408
EF-100T-199E-3N(A)	379		58.6	58.6	98.5	1972	718	1588	327	1899	127	1857	1524	38	19	19	408
EF-100T-250E-3N(A)	379		73.2	73.2	97.0	1972	718	1588	327	1899	127	1857	1524	38	19	25	408
EF-100T-300E-3N(A)	379		87.9	87.9	92.0	1972	718	1588	327	1899	127	1857	1524	38	19	25	408
EF-100T-399E-3N(A)	379		117.2	117.2	94.0	1972	718	1600	330	1861	127	1857	1524	38	25	25	431

For propane gas models change suffix "N" to "X" and remove "E" from the model number. **Example: EF-100T-150-3X**

(A) ASME - All models are available with ASME construction. To order ASME construction add the (A) to the end of the model number.

Example: EF-60T-125E-3NA

For 5 year warranty models, change suffix "3" to "5" **Example: EF-100T-399E-5N**

Note: The weight is the same for both ASME and Non-ASME models.

All models comply with the latest ultra-low NOx requirements of 14 ng/J or less.

14.0" w.c. maximum static, 4.5" w.c. minimum running (recommend 7.0" w.c. minimum running)

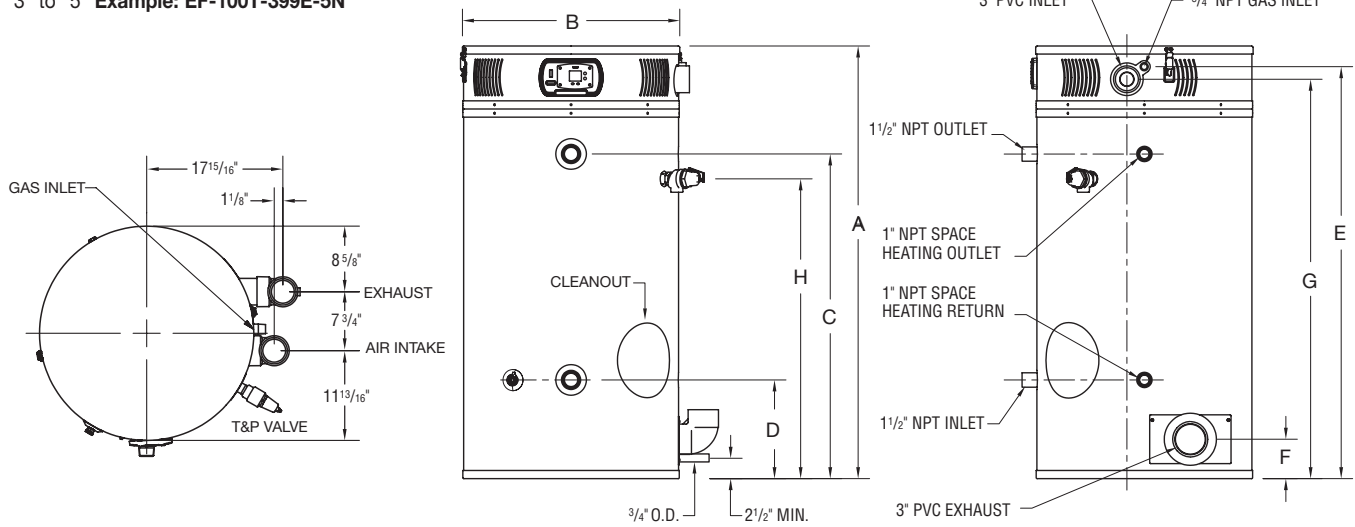

Note: Diagrams are for both 60 and 100 gallon models.

Recovery Data

Model Number	GPH Recovery at Degree Rise*												LPH Recovery at Degree Rise*											
	30°F	40°F	50°F	60°F	70°F	80°F	90°F	100°F	110°F	120°F	130°F	140°F	17°C	22°C	28°C	33°C	39°C	44°C	50°C	56°C	61°C	67°C	72°C	78°C
EF-60T-125E-3N(A)	485	364	291	242	208	182	162	145	132	121	112	104	1836	1378	1102	916	787	689	613	549	500	458	424	394
EF-60T-150E-3N(A)	564	423	338	282	242	211	188	169	154	141	130	121	2135	1601	1279	1067	916	799	712	640	583	534	492	458
EF-60T-199E-3N(A)	740	558	444	370	317	277	247	223	202	185	171	159	2801	2112	1681	1401	1200	1049	935	844	765	700	647	602
EF-100T-150E-3N(A)	601	450	360	300	257	225	200	180	164	150	139	129	2275	1703	1363	1136	973	852	757	681	621	568	526	488
EF-100T-199E-3N(A)	792	597	475	396	339	297	264	239	216	198	183	170	2998	2260	1798	1499	1283	1124	999	905	818	750	693	644
EF-100T-250E-3N(A)	980	735	588	490	420	367	327	294	267	245	226	210	3710	2782	2226	1855	1590	1389	1238	1113	1011	927	856	795
EF-100T-300E-3N(A)	1115	836	669	558	478	418	372	335	304	279	257	239	4221	3165	2532	2112	1809	1582	1408	1268	1151	1056	973	905
EF-100T-399E-3N(A)	1519	1127	912	760	651	570	506	451	414	380	351	326	5750	4266	3452	2877	2464	2158	1915	1707	1567	1438	1329	1234

Commercial Gas High Efficiency Water Heater

Sample Specification

The water heater shall be a Bradford White model EF-_____ with a rated storage capacity of not less than _____ gallons/ liters, a minimum gas input of _____ BTU/hr., a minimum recovery of _____ GPH/LPH at 100°F (56°C) temperature rise, and a Thermal Efficiency Rating of ____%. It shall be design certified by CSA International (formerly AGA and CGA) for 180°F (82°C) application, either with or without a separate storage tank. The tank shall be lined with Vitraglas® vitreous enamel and shall have a bolted hand hole cleanout. The tank shall have four extruded magnesium anode rods installed in separate head couplings. This water heater shall be equipped with stainless steel cold water inlet, Hydrojet® Sediment Reduction System. The heater shall be insulated with Non-CFC foam. This water heater shall be equipped with an electronic ignition system, an ASME rated T&P relief valve and a premix closed combustion system for direct venting using either 3" (76mm) or 4" (102mm) PVC, CPVC or ABS vent pipe. (115V AC required). The water heater shall be factory assembled and tested. The water heater shall be approved for zero inch clearance to combustibles. A digital LCD display shall be integrated into the front and be an adjustable electronic thermostat to any temperature up to 180°F. A recycling Energy Cut Off (E.C.O.) shuts off all gas in the event of an overheat condition. The entire installation shall be made in compliance with state and local codes and ordinances.

General

All gas water heaters are certified at 300 PSI test pressure (2068 kPa) and 150 PSI working pressure (1034 kPa). All models are design certified by CSA International (formerly AGA/CGA), ANSI standard Z-21.10.3, for up to 180°F (82°C) application as an Automatic Storage Heater. As an Automatic Storage Heater, all models are complete, self-contained water heating systems. It needs no separate storage tank, pump, wiring or elaborate piping network. When equipped with a mixing valve, it will supply 180°F (82°C) sanitizing and lower temperature general purpose hot water simultaneously. These models can be used either as a single unit or in multiples connected in series or parallel (recommended).

Dimensions and specifications subject to change without notice in accordance with our policy of continuous product improvement.



Ambler, PA

For U.S. and Canada field service, contact your professional installer or local Bradford White sales representative.

Sales 800-523-2931 • Fax 215-641-1670 / Technical Support 800-334-3393 • Fax 269-795-1089 • Warranty 800-531-2111 • Fax 269-795-1089

International: Telephone 215-641-9400 • Telefax 215-641-9750 / www.bradfordwhite.com

 **BRADFORD WHITE-CANADA**® INC. Sales / Technical Support 866-690-0961 / 905-238-0100 • Fax 905-238-0105 / www.bradfordwhite.com

Built to be the Best™

©2017, Bradford White Corporation. All rights reserved.